



BREATHER MEMBRANES INSTALLATION ACCESSORIES

FAKRO COMPANY

Reliable partner

Fakro Company, founded in 1991, is one of the largest and fastest growing roof window companies in the world today. Fakro range includes: roof windows, access roof lights and loft ladders. Fakro also offer a wide range of roof window accessories. Fakro products are sold in most countries in the world.

Many years' experience

As an expert in the roof window industry we have expert knowledge in how to secure the window's tight connection with the roof slope and how the cross section of the roof construction should look.

Wide range of products

Our range of roof underlays and membranes is the result of extensive professional knowledge and market demand. Thanks to many years' experience gained on Polish and other European roofs, our company introduced to the market flashings: an air-permeable underfelt flashing made from Eurotop breather membrane and a water vapour air-tight flashing. These products enable a secure connection of the roof window with air-permeable underlay and vapour-proof film to be made.

The highest quality - constant control

All Fakro breather membranes are products with the highest technical characteristics. They are under the permanent control of the Quality Control Department and such characteristics as: resistance to tear (nail shank), head of water(waterproofing), roll length and width, roll weight are regularly checked. As well as this standard quality monitoring, a number of additional tests are also done which confirm the highest quality of products sold under the Fakro brand name.



Device used to test UV exposure tolerance (UV-SUNTEST)



Testing the resistance of underlay to tear

MEMBRANES AND ROOF UNDERLAYS

Breather membranes

Economy

The membrane can be laid directly onto insulation and allows it to be used at full rafter height, which enhances the insulating properties of the roof. The high water vapour permeability and waterproofing of Eurotop membranes ensures that the insulating material is dry. It also means that high thermal insulating properties are secured. Windproof properties of the membrane and the lack of ventilation gap between the insulating material and membrane does not allow heat to be drawn away from the insulation and prevents moisture absorption from the air. Very easy installation of membranes lowers the cost of installation and minimises the risk of costly repairs as a result of installation mistakes.

Easy installation

The lack of ventilation gap facilitates all the works connected with proper installation of thermal insulation and lowers the cost of the roof construction. There is no need to increase the roof thickness in

order to gain the proper space required to be insulated in accordance with Building Regulations.

Permeability

Thanks to the high permeability the moisture excess vaporises which enhances the durability of the roof construction and also secures a dry and comfortable environment in the loft.

Waterproof

The membrane protects the loft against rain, moisture and dust. It also guarantees that leaks in roofing material or water which comes from melting snow or condensation will be taken outside the roof and will not enter into the insulating layer.

Temperature resistance

Fakro offers membranes with a high temperature resistance and can be applied to roofs with metal sheet coverings as well.

High vapour permeability membranes

Eurotop membranes can be applied as initial roof covering material to steep roofs and also to external walls. They combine unique parameters like waterproofing and water vapour diffusion. High waterproofing properties protect against the passage of drops of water into the thermal insulation. High vapour permeability means that thermal insulation can be laid directly onto membrane without the necessity of applying a ventilation gap to the roof construction or wall. Thanks to this the layer of insulating material can be thicker and as a result will save energy. All Fakro membranes are equipped with function film.

technical characteristics	EUROTOP N35
weight [g/m ²] EN 1848-2	135
water vapour permeability [g/m ² /24h]	ca. 1500 g/m ² /24h BS 3177 at 25°C/75% RH ca. 3200 g/m ² /24h ASTM E398-83 at 38°C/85% RH
head of water [m] BS EN 20811	ca. 5500 mm H ₂ O
tensile strength EN 12311-1	MD 270 N/5 cm CD 170 N/5 cm
vapour resistance BS 3177	0.14 MN sg ⁻¹
resistance to tear (nail shank) BS EN 12310-1	MD 120 N/5 cm CD 120 N/5 cm
UV exposure tolerance	3 months
heat resistance	- 40°C to +120°C
color top/bottom	green top surface/white under surface
SD-value COBR PIB nr 64	0.015 m
roll width EN 1848-2	1.5 m
roll length EN 1848-2	50 m
roll weight	ca. 10.5 kg
BBA Certificate	05/4292
other	can be applied on boarded roofs



TECHNICAL/CONSTRUCTION GUIDANCE

FAKRO *EUROTOP N35* breather membrane – BBA certified for all roof constructions as an unsupported or fully supported roof lining material for tiled or slated pitched roofs constructed in accordance with the relevant clauses of BS 5534: 2003.

Roof categories

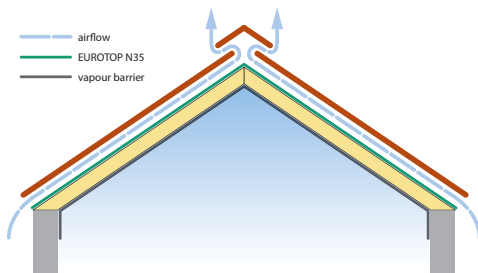

warm roof – (roof system using a breathable membrane laid directly on the insulation or insulated sarking board, with the insulation following the roof pitch and with no cross ventilation through the roof space)*

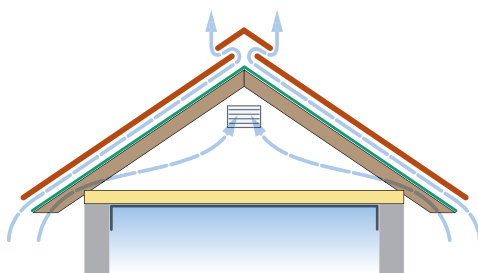

cold roof ventilated – (roof system where there is either no insulation or insulation at ceiling level and cross ventilation through the roof space)*

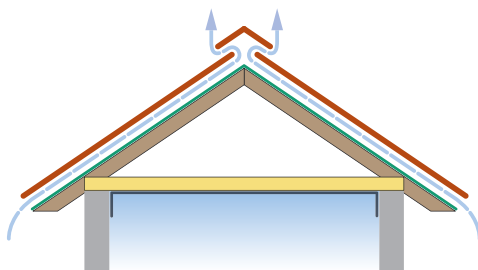

cold roof unventilated – (roof system using a breathable membrane with insulation at ceiling level, and no cross ventilation through the roof space)* sealed (roof system using a breathable membrane with insulation at ceiling level, no cross ventilation through the roof space and any overlaps and penetrations sealed to prevent air movement other than through the membrane)*

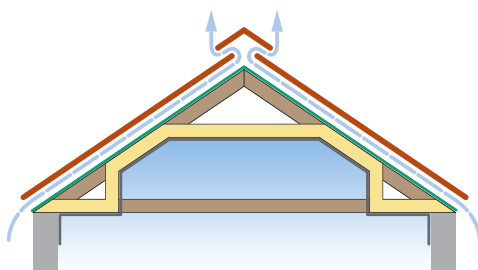

hybrid roof – (a roof system with insulation following the roof pitch, no cross ventilation through the roof space and ventilation gap between the insulation and the underlay)*

* Definitions from M.O.A.T. No 69: 2004 UEAtc Technical Report for the Assessment of Discontinuous Roofing Underlay Systems – mandatory for BBA Certification process *EUROTOP N35* Roof Tile Underlay must be installed and fixed in accordance with the BBA Certificate No. 05/4292 and the relevant recommendations of BS 5534: 2003* and BS 8000-6: 1990*. Installation can be carried out under all conditions normal to roofing work.

* BS 5534: 2003 Code of practice for slating and tiling (including shingles)

* BS 8000-6: 1990 Workmanship on building sites — Code of practice for slating and tiling of roofs and claddings

Condensation

For design purposes*, the *EUROTOP N35* may be regarded as a type 'LR' membrane. The complete roof construction, ceiling boards to roof tiles, must be considered as a total system with regard to condensation risk. It is recommended to install a vapour control layer/ vapour check plasterboard or vapour barrier.

Cold non-ventilated roofs:

- All penetrations into the roof space must be properly sealed and loft hatches made convection tight by, for example, using a compressible draught seal. Vent stacks, boiler flues, for example passing through the roof space, must additionally be sealed along their length.
- Subsequent penetrations into the roof space must be properly sealed to ensure that the integrity of the non-ventilated, cold-pitched roof system is maintained. This can be achieved by the use of butyl adhesive tape.
- It is essential to limit the rate of water vapour transfer into the loft space from the dwelling below.

Appropriate measures include:

- The dwelling below the roof must be ventilated in accordance with national Building Regulations and Standards for the dispersal and rapid dilution of water vapour. Extractor fans should be used in rooms that may experience high humidity such as kitchens, utility rooms and bathrooms. The ventilation rates should be in accordance with the guidance documents supporting current national Building Regulations and Standards.
- All water tanks in the loft space should be covered and all pipe-work lagged; penetrations into the loft space from inside and outside must be sealed. Sealing should also be in accordance with the Certificate holder's instructions to allow water vapour to disperse above the product, tiling battens (minimum thickness 25 mm) must be used to ensure an air space between the roof covering and the product. The insulation, laid horizontally at ceiling level, is pressed tightly into the eaves against the underlay to ensure no gaps are present.

Detailed ways to limit the risk of condensation are defined in the national Building Regulations and Standards: England and Wales (Approved Document C) Scotland (Mandatory Standard 3.15) Northern Ireland (Regulation C5), BS 5250: 2002 – Code of practice for control of condensation in buildings.

* Roofs designed in accordance with BS 5534: 2003



Insulated warm pitched roof types

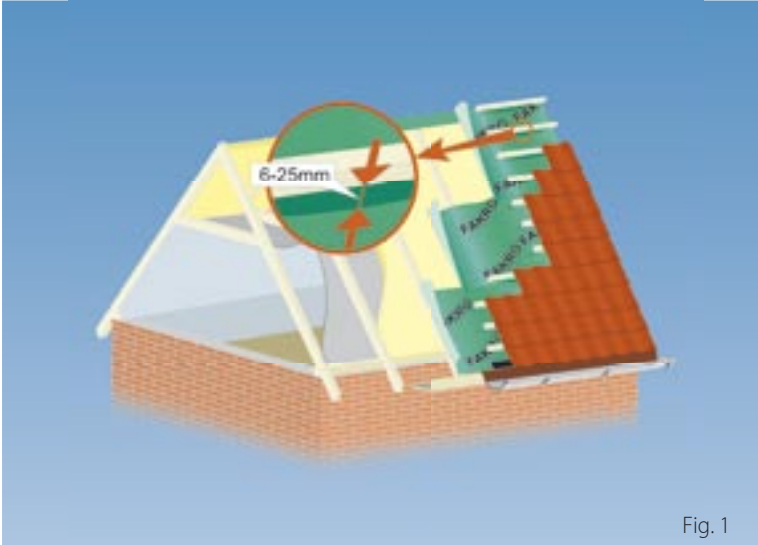

Fig. 1

I. Unsupported - Membrane taut or draped between the rafters

1. Membrane to be taut when counter-battened. If there is installed a breather membrane and counter-battens it is preferable to make membrane supported on installation.
2. Membrane to be draped without counterbattens (drape between 6 to 25 mm). (Fig. 1)

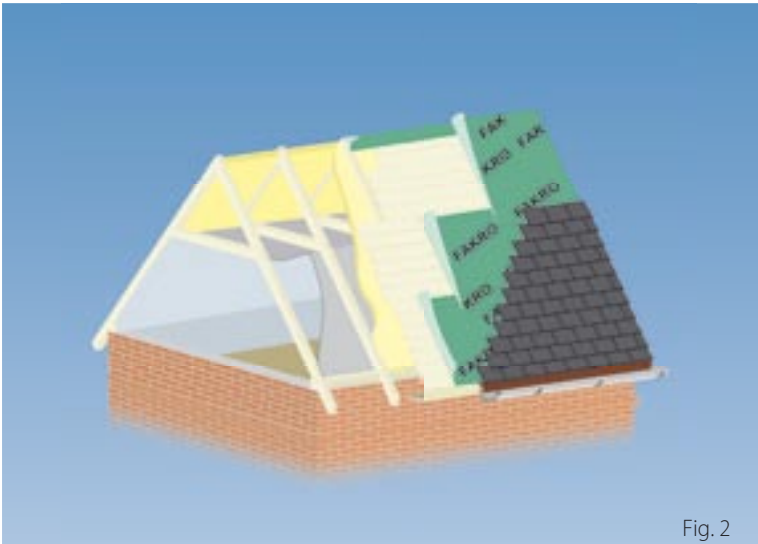

Fig. 2

II. Supported - Membrane laid directly onto the sarking/plywood

On boarded roofs, *EUROTOP N35* is best installed using the horizontal overlapping method.

1. Counter-battened
2. Scottish practice, with slates nailed through the membrane directly onto timber planks (nominally 150 mm wide with a 2 mm gap) without battens. (Fig. 2)
3. Without air gap between sarking and insulation (when using plywood- necessary air gap between insulation and plywood or any other vapour barrier supporting layer).

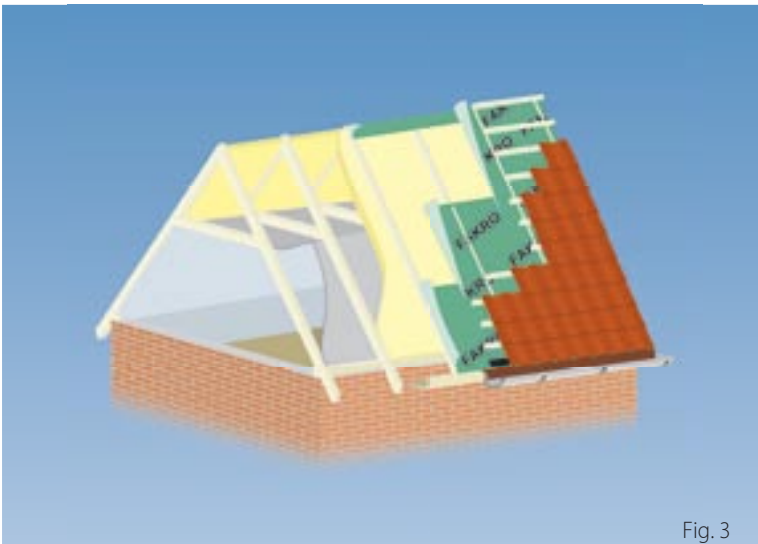
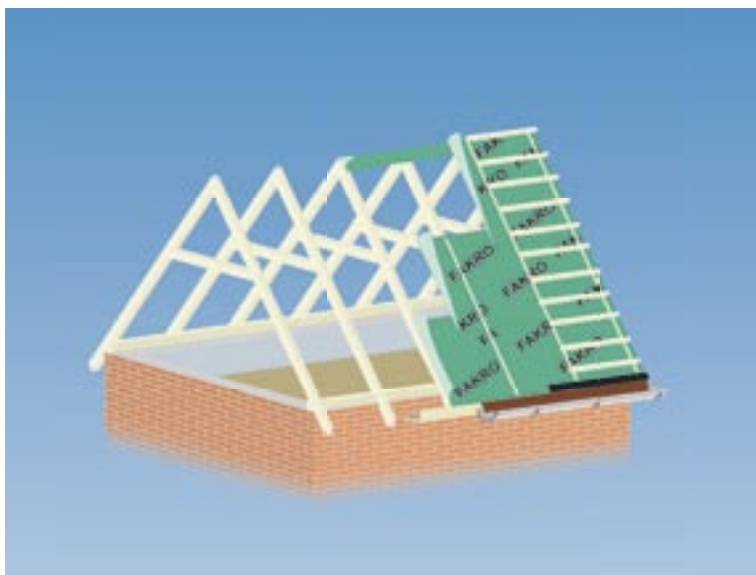

Fig. 3

III. Membrane laid directly onto the insulation

1. Counter- battened (Fig. 3)

DETAILS



Laying – the product is installed with the coloured or printed side uppermost and lapped to shed water down the slope. **EUROTOP N35** is first nailed with roofing nails directly to rafters, then it is counter-battened, according to requirements, parallel or perpendicular to the eaves. When laid in the perpendicular, the overlaps should be sealed with adhesive tape (suitable for this purpose).

Overlaps – must be provided with the minimum dimensions given in table.

Roof pitch (°)	Horizontal lap (mm)		Vertical lap (mm)
	Fully supported	Not Fully supported	
12.5 to 14	150	225	100
15 to 34	100	150	100
35 +	75	100	100

Tiling battens – to allow dispersion of water vapour, tiling battens must be a minimum of 25 mm thick, except Scottish practice. The product can be installed by draping over rafters and securing with tiling battens, or installed taut over rafters and secured with counter battens and tiling battens (minimum 25 mm thickness).

Duo-pitched – roofs (ridge) - the last length of the membrane applied at the ridge must have an overlap of at least 15 cm over the apex, in order to cover the roof ridge twice.

Eaves – in closed eaves construction, the use of eaves guards is recommended. At the eaves, **EUROTOP N35** should be sealed with adhesive tape (e.g. butyl), so that the bottom edge lies over the gutter or lies on a felt support tray. At the eaves, a minimum exposure to the elements should be observed.



Roof windows – around roof windows we advise you to install a FAKRO XDP underfelt collar (with attached additional insulation material. Extractors, soil pipes, and aerials etc., pierce the membrane. Cut out a star shape in the **EUROTOP N35**, and then turn it up, glue and seal around the protrusion with adhesive tape, and above the hole place a gutter.



Exposure – whilst *EUROTOP N35* may remain unprotected for 3 months, it is recommended that good practice is followed and tiles or slates are installed as soon as possible. The product resists penetration of water to a head, and consequently may be used as temporary waterproofing prior to the installation of slates or tiles. The period of such use should, however, be kept to a minimum.

Counter battens – the product is secured to the support with counter battens at least 25 mm thick to create an air space between the product and the tiles for drainage and vapour dispersal. The counter battens should be fixed with corrosion-resistant staples or galvanized clout nails as appropriate. Tiling battens are secured to the counter battens and supported with appropriate fixings. When *EUROTOP N35* is installed as an unsupported system, it is fixed in the traditional method for roof tile underlays, i.e. draped between the rafters.

Service penetrations – for these, chimneys and roof lights, the membrane should be dressed a minimum of 100 mm to the up-stand and sealed effectively by an appropriate flashing. Adequate soakers should be provided above any holes or openings.

Hips and valleys – should be covered with a 600 mm wide strip of *EUROTOP N35* roof tile underlay. In the valley you must seal all cracks, splits and overlaps and you should also seal around the corners with butyl adhesive tape.

Verges – to protect vertical walls against moisture ingress the membrane should be lapped over the outer walling by at least 50 mm. Where the verge has a constructed overhang, the membrane should be fixed to the outer rafter.

Abutments – the membrane should be turned up at least 75 mm or be taken behind lead flashing and sealed.

Chimneys, roof windows, etc., you should seal *EUROTOP N35* around with butyl adhesive tape, so that the upturned parts of the membrane create a seal of in 5-15 cm. Above skylights, chimneys, roof windows, and roof hatches etc. you should make small gutters of *EUROTOP N35*. These gutters protect against thawing drips, or wind driven rainfall leakage.

Handling & storage – the membrane must be handled and stored with care to avoid damage and moisture. Rolls should be stored flat or preferably on end, away from direct sunlight, on a clean level surface inside a dry storage area. *EUROTOP N35* may also be used as wind insulation in wooden and metal framework walls. For sealing *EUROTOP N35* during installation you should use butyl adhesive tape, designed specifically for this purpose. We request *EUROTOP N35* installers do not smoke cigarettes during installation of *EUROTOP N35*. Cigarette ash can burn small holes in the membrane, which is difficult to notice, and can cause leaks. We would warn against strong acids and alkalis being used as preservatives as they may damage the membrane's active layer, and any other metal coated products. During the roof membrane installation, damage can occur and any tears and rips should be repaired as soon as possible with butyl tape and patches of the membrane. The water tightness and integrity of the product should be paramount at all times.

Above are listed the most important, and basic recommendations, but does not include information concerning other possible solutions used in roof constructions. There are also situations, where solutions other than those described in this literature may be applied.

FAKRO ROOF WINDOW INSTALLATION ACCESSORIES

Water vapour permeable underfelt collar XDP with thermal insulation

An water vapour permeable underfelt collar is used for easy fitting of the window in conjunction with the Water vapour permeable sheeting used in roof construction. Manufactured using the highest quality water vapour permeable membrane (EUROTOP).

The sides of the collar are made in such a way that they can be placed directly onto roof battens, irrespective of the spacing between them or their thickness. Adequate methods of connection made in the corners secures the water tightness of the collar.

In the package together with the collar, there is insulating material made of sheep's wool which is used to achieve thermal insulation between the battens and around the window. Sheep's wool is specially impregnated so that it has proper density and elasticity and is proven to be a perfect insulating material. Collars should be chosen according to window size.

Features:

- is waterproof and therefore it protects the frame of the window against moisture
- contains thermo-insulating material
- requires no dismantling of battens and cutting of counter-battens
- speeds up and facilitates installation
- secures proper connection of roof underlay with the window
- its high vapour permeability enables evaporation of moisture
- applies to all window sizes, including non-standard
- suitable for roof with pitches between 15° and 90°.

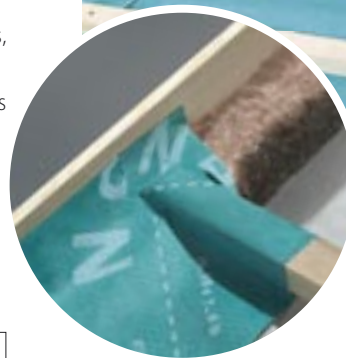
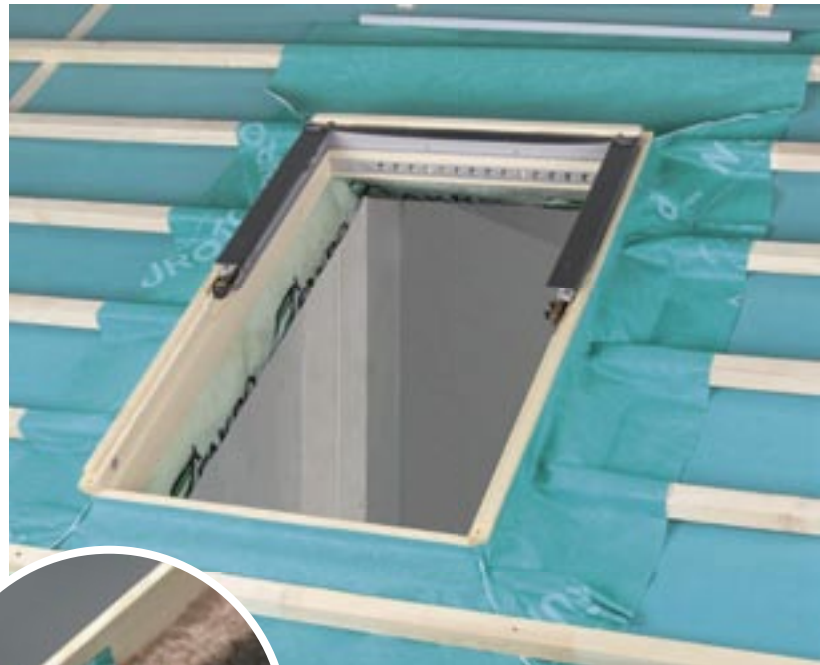

thermo insulating material

vapour permeable under felt collar XDP

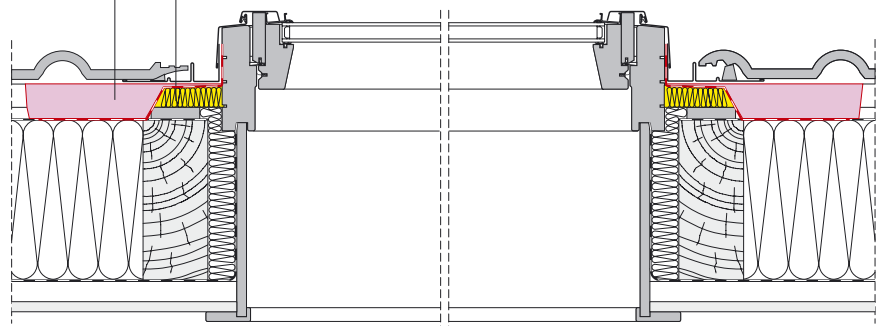

horizontal cross section of the FTP-V window with vapour permeable collar XDP

Vapour barrier collar XDS

Vapour barrier collar should be secured internally, to form a barrier against warm and humid air, as any moisture on the surface of the insulation greatly reduces its thermal insulation properties. For this reason any possible leaks should be eliminated. Fakro offers a ready-made solution – vapour barrier collar XDS. This ensures a flush fit between the roof window and sheeting. The sheeting is pushed into a groove specifically made in the window's frame. In the package with the vapour barrier collar (made of polythene film) there is an additional installation kit to make the connection of the flashing with the frame and with vapour permeable membrane. The installation kit contains double-sided adhesive butyl tape to connect the collar with the frame of the window and waterproofing and protection from ageing, one sided adhesive tape to secure connection of the collar with vapour permeable membrane. The collar should be chosen in accordance with the size of the window.



Features:

- protects insulation material from dampness, and heat and moist air-transmittance
- guarantees vapour barrier between window and membrane
- quick and easy to assemble
- the package contains two rolls of double-sided adhesive butyl tape and one roll of one-sided tape
- can be used for roof pitches between 30° and 60°
- applies to all window sizes, including non-standard.

Fakro installation accessories – guarantee of high quality, quick and easy installation

Fakro installation accessories ensure the best connection of the window with the roof covering material.

Applying water vapour permeable underfelt collar with thermo insulation and vapour barrier collar creates a system which secures the Fakro roof window installation.

Only using original accessories assures long and safe use of Fakro roof windows.

Installation accessories reduce the risk of thermal bridging.

Installation accessories guarantee that moisture from the surface around Fakro roof windows flows away efficiently.



Fakro GB Ltd
Fakro House
Astron Business Park
Hearthcote Road
Swadlincote
DE11 9DW
Telephone : 01283 554755
Fax : 01283 224545
www.fakro.com
e-mail: sales@fakrogb.com